

FlowCon Green / GreEQ



Pressure Independent Control Valves with 100% Authority

The FlowCon Green / GreEQ insert is designed as a 3-in-1 solution combining a full stroke modulation control valve, an automatic balancing valve and a differential pressure control valve. This insert includes an innovative diaphragm-based self-adjustment feature, which enables each valve continuously to self-balance. This ensures delivery of precisely the flow rate required by each terminal unit, independent of pressure fluctuations in the system. In addition, each insert can be adjusted to set an accurate maximum flow limit to each circuit without stroke limitation.

The FlowCon Green / GreEQ is a 100% authority pressure independent flow control valve which instantaneously self-balance at all points of operation, even when there is variance in pressure differential. As long as the pressure differential across the valve is within the operating range, the valve diaphragm is regulating nonstop ensuring constant differential pressure across the regulating element and thereby ensuring full authority. FlowCon Green / GreEQ will in other words always provide 100% authority for

any of its stepless-set 41 maximum flow settings, while maintaining full spindle stroke.

- **3-in-1 combi valve**, including modulating control valve, dynamic flow limiter and differential pressure control valve in one body.
- **100% authority pressure independent.**
- **Full stroke modulation** at any design flow.
- **Multiple Control Characteristics** available: Linear (Green) or Equal% (GreEQ) insert and Linear or Equal% actuator.
- **Easy solution to designers, installers and end-users** - due to its flexible complete solution and user-friendly setting.
- **Quick commissioning** as the insert can be **pre-set** prior to site-work or be **field adjustable** on demand.
- **Serviceable** - the insert can be adjusted or exchanged without removing the housing from the system.
- **"Sealed" setting** - actuator will cover the setting and **protect against tampering.**

FlowCon Green / GreEQ

Pressure Independent Control Valves with 100% Authority

PICV with Actuator

Maintains correct flow despite pressure changes and guarantees that flow and actuator position only change when demand requirements change.

Size: DN15-40 / 1/2"-1 1/2".

Max. operational ΔP : 800 kPaD / 116 psid.

Max. flow rates: 0.005-1.29 l/sec / 0.076-20.4 GPM.

Media temperature: -20°C to +120°C / -4°F to +248°F.

Static Pressure: 2500 kPa / 360 psi.

Housings

The FlowCon Green / GreEQ insert can be used with the following FlowCon housings:

- FlowCon A - DN15-25 (1/2"-1").
- FlowCon AB - DN15-32 (1/2"-1 1/4").
- FlowCon ABV - DN15-40 (1/2"-1 1/2").

Green / GreEQ Inserts

The insert range covers 20 mm / 3/4" insert in high and low ΔP as well as one 40 mm / 1 1/2".

FN, FNR and FT Actuators

FN: electrical actuators 0(2)-10V modulating, 3-point floating or 2-position.

FNR: electrical actuators 0-10V modulating, 3-point floating or 2-position.

FT: thermal actuators 0-10V modulating or ON/OFF.

Applications

Heating or cooling, Fan-coil units, Air-handler units and other terminal units - wherever dynamic balancing and fully accurate temperature control are required.

For further information visit www.flowcon.com

Application Example

Fan Coil Unit with Pressure Independent Control (PICV) - Modulating Control.

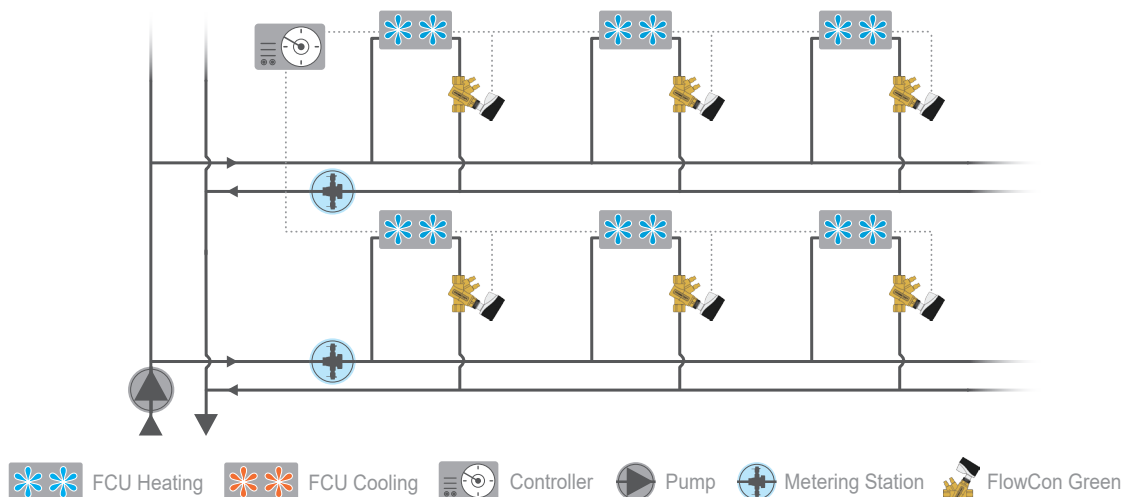

FlowCon
international

A Griswold Controls LLC./FlowCon International Company

www.flowcon.com

DENMARK • DUBAI • USA • CHINA • SINGAPORE